

Cumberland High School

Excellence in Education

183 Pennant Hills Road, Carlingford NSW 2118

Phone: 02 9871 7718 Fax: 02 9872 5381

www.cumberland-h.schools.nsw.gov.au

Email: Cumberland-h.school@det.nsw.edu.au



Above: Members of the Interface Leadership team
Right: Mr Brendan Hogan, Interface, presenting the awards

Above: Members of the Leo Club team
Right: Mr David Evans and Mr Steven Hirsch, Lions Club Carlingford/Dundas, presenting the awards

Important Dates & Events 2019, TERM 4	
NOVEMBER	
25 – 29 Nov	• Yr12 Neal Hospitality Work Placement (1 of 2 weeks)
27 Nov	• Year 6 to Year7 Transition Visit (2 of 2)
DECEMBER	
2 – 4 Dec	• Year 7 Water Skills (3 days)
2 – 6 Dec	• Yr12 Neal Hospitality Work Placement (second week)
3 Dec	• Year 7 2020 Orientation Day
4 Dec	• P&C Meeting 7pm
5 – 9 Dec	• Band Tour (5 days)
9 – 13 Dec	• Yr12 Pillay Hospitality Work Placement (1 week)
12 Dec	• PRESENTATION DAY
13 Dec	• School Reports issued
16 Dec	• End of Year Excursions
18 Dec	• LAST DAY FOR 2019!!!

Celebrating our Student Leadership

Term 4 is an extremely busy and exciting time for all as the year draws to an end. Years 7 – 10 are working on their final assessments for the year and Year 11 has started the HSC course.

Earlier this week, we invited parents and guests to celebrate at our Leadership assembly. Some of the opportunities were within the school and some with external agencies. The common element of these programs is that they all enhance student capacity, involvement and leadership skills in many different ways. Student leadership at Cumberland High School truly reflects the quality of students we have in our school.

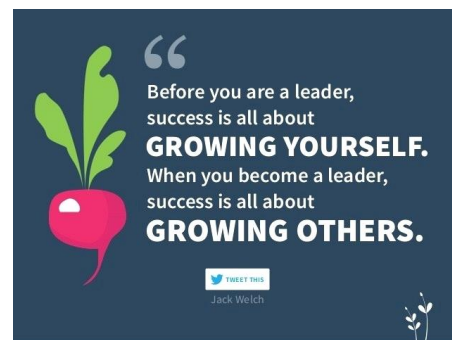

COSfest 2019 proved a huge success this week. Our catering team, under the guidance of Mr Pillay, did an outstanding job serving food and coffee to over 300 students and their parents from the Community of Schools. Our 9 partner primary schools are; Carlingford West, Carlingford, Dundas, Ermington West, Rydalmere, Rydalmere East, Yates Avenue, Oatlands and Burnside. What a wonderful celebration!

We are excited to be planning for our Orientation day for Year 7 2020 on Tuesday 3rd December. Our peer support leaders are ready to showcase our school and enable a smooth transition for our incoming students. Our Year Advisors for 2020 Mr Josh Wilson and Mr Aaron Langdon, eagerly await the fresh faces of our students.

Last week, Year 10 and 11 completed their HSC Minimum Standards Testing. Together with the NSW Literacy and Numeracy Strategy, the HSC minimum standard is part of an effort to improve the literacy and numeracy outcomes for students. This means that students who demonstrate the standard have the reading, writing and numeracy skills needed for everyday tasks, work and further study. Students will receive their results soon. A catch up day will be announced soon for any students who may have missed the test.



Next week, Year 10 will be completing the “All My Own Work” Program. This is a program designed to help HSC students follow the principles and practices of good scholarship. This includes understanding, valuing and using ethical practices when locating and using information as part of their HSC studies. Students who have completed the program will also know about penalties for cheating and how to avoid malpractice when preparing their work for assessment.

This is a compulsory department program that all students in Year 10 must complete before moving into Year 11. Mrs Alexander has planned for all students to complete this program on Monday 25th November.

Presentation Day will be held on Thursday 12th December. Students receiving an award will receive their invitation by the end of week 8.

Mrs J Ashton
Relieving Principal



Student Leadership Awards



Brekky Club Team

Coordinator and Award Presenter: Ms Letitia McCubbin

Debbie Adeniyi-Kazeem
Pauline Bal
Phoenix Hart-Suberu

Purvi Kapur
Hana Ortega
Zashaal Shahid

Zahli Stewart
Izabella Vardy
Zayne White

Clean Up Australia Day Team & Environment Advocate

Coordinator and Award Presenter: Mr Michael Pillay

William Ballard
Grace Deng
Siya Dhawan
Maddison Drennan
Hari Ganesa Balaji
David Kim

Joshua Kim
Jeein Lee
Aatam Madar
Liam Mai (+ Environment)

John Paterson
Sidharth Pradhan
Anannya Puri
Niaz Saidi
Sana Yousefi
Wasay Zuberi



The Community Of Schools Team

Coordinator: Ms Mechel Pikoulas
Awards presented by Mr Michael Pillay

Siya Dhawan

Arnav Kale
Emma Kunjasich

Daniel Zolmajdi

Cumberland Cafe Team

Coordinator and Award Presenter: Mr Michael Pillay

Kyrah Armstrong
William Ballard
Maddison Drennan
Christopher Fong
Jihan Ghabach
Yijian (David) Guo

Kate Haswell
Crystal Kondoulis
Emma Kunjasich
Cameron McLean
Mona Pourmanaf
Anannya Puri

Adwithiya Puri
Hollie Skinner
Ysabelle Vicente
Luke Welsh
Dieter Zadow





Student Leadership Awards



Drama Club

Coordinator and Award Presenter: Mr Daniel Simmonds

Natasha Chandler
Rowan Chate
Connor Evans
Jihan Ghabach

Isaac Hemsworth-Smith
Emily McLean
Mei Ortega
William Smedley

Sophia Warnecke
Shaun Younger
Sophie Younger



Ensembles Program

Coordinator: Mr Martin Andrews
Awards presented by Ms Mi-Yong Son

Rowan Chate

Karina Hoyle

The Future Project Team

Coordinator and Award Presenter: Mr Mark Walford

Rowan Chate

Dylan Lay

Adwithiya Puri



The Helmsman Project Team

Coordinator: Ms Mechel Pikoulas
Awards presented by Ms Madeline Wolfe and Mr Josh Wilson

Faith Adeniyi-Kazeem
Serena Carvajal
Aariz Ery Edzaputra
Patrick Kang
Pamela Koutoulas

Zenas Lister
William Low
Gaurav Madar
Saurav Madar
Caitlin Maddocks

Johnavon Manurung
Erin McLean
Rohan Nelson
Georgia Ryan
Alwin Zhao



Student Leadership Awards



Interface®

Interface Team

Coordinators: Miss Sam Coster and Mr Chris Lummis

Awards presented by Mr Brendan Hogan, Interface Australia/New Zealand

Husain Alhashemi
Charlotte Ballard
Fay Bekiaris
Kathleen Birrell
Rowan Chate
Zixin (Jacinta) Chen
Dev Chopra

Rebecca Edmonds
Vivian Ha
Gabriel Hardtke
Sarah Haswell
Nihar Kadkol
Purvi Kapur
Dylan Lay
Marcel Lister

Zenas Lister
Samuel Meguerditchian
Adwithiya Puri
Enrico Rapisura
Hannah Smedley
Elizabeth Thompson
Dieter Zadow



IRIS Conference (Yorkshire) Team

Coordinators and Award Presenters: Miss Sam Coster and Mr Chris Lummis

Fay Bekiaris
Kathleen Birrell
Rowan Chate

Dev Chopra
Rebecca Edmonds
Purvi Kapur

Samuel Meguerditchian
Adwithiya Puri



Leo Club Student Members

Coordinator: Ms Mechel Pikoulas

Awards presented by Mr Steven Hirsch and Mr David Evans, Lions Club Carlingford/Dundas

President - Purvi Kapur
Vice President - Mei Ortega
Secretary - Abirami Narenthiranathan
Treasurer - Corelle Spagnolo
Publicity Officer – Georgia Haddock
Debbie Adeniyi-Kazeem
Pauline Bal

Charlotte Ballard
Zixin (Jacinta) Chen
Dev Chopra
Shreeya Deshpande
Naman Ganjekar
Aishwarya Gudodgi
Joanne Lee

Muskan Nazari
Merjan Onus-Ehsani
Adwithiya Puri
Anannya Puri
Zashaal Shahid
Valerie Wijaya
Elizabeth Willcox





Student Leadership Awards



Library Leadership Team

Coordinator and Award Presenter: Ms Karen Alexander

Aditya Agnihotri
Husain Alhashemi
Pauline Bal
Portia Bal
Charlotte Ballard
Rowan Chate

Zixin (Jacinta) Chen
Peter Duke
Vivian Ha
Acshathan Haran
Daniel Japardi
Zenas Lister

William Low
Jaineel Devang Pathak
Sai Sriman Tadepalli
Vedant Trivedi
Hyun Jin (Blayke) Yoo



Peer Tutoring Students

Coordinator and Award Presenter: Mr Andrew Fahey

Charlotte Ballard
Fay Bekiaris
Vivian Ha

Rachel Harkin
Daniel Japardi
Jocelyn Lay

Farnia Nazififar
Patrick Ryan
Negar Sanati

Science Inspire Team

Coordinator and Award Presenter: Ms Krystyna Stead

Aditya Agnihotri
Husain Alhashemi
Charlotte Ballard
Manav Bansal
Yuling (Cynthia) Chen
Dev Chopra
Sonya Duke
Rachael Edmonds
Rebecca Edmonds

Yena Ju
Nihar Kadkol
Michael Lape
Zenas Lister
William Low
William Lukman
Ericka Nguyen
Adwithiya Puri
Olivia Skeoch

Hannah Smedley
William Smedley
Sai Sriman Tadepalli
Julia Tapiador
Jennifer Todorovski
Vedant Trivedi
Alexander Warnecke
Ingrid Yoo
Alwin Zhao



Sport Teams Assistant – Yr 7

Award presented by Mr Josh Wilson

John Paterson

Student Photographers

Coordinator and Award Presenter: Ms Rachael Maher

Danial Amin Rahmanlou

James Darcovich

Oliver Sadzak





Student Leadership Awards



Student Representative Council

Coordinators: Ms Sharon Bower and Ms Breanna Hoppe
Awards presented by Ms Breanna Hoppe



Malia Afridi
Fay Bekiaris
Krittika Biswas
Rowan Chate
Zixin (Jacinta) Chen
Grace Deng
Vidushi Gupta
Harish Haran

Rachel Harkin
Kate Haswell
Sarah Haswell
Isaac Hemsworth-Smith
Purvi Kapur
Aisleen Lay
Dylan Lay
William Low
Sam Meguerditchian

Merjan Onus-Ehsani
Makenzie O'Shea
Adwithiya Puri
Negar Sanati
Amber Thalakkottur Sajan
Nahyeon Thomas
Elizabeth Thompson
Ali Zubairi



World Teachers Day and International Womens Day Breakfast Volunteers

Coordinator and Award Presenter: Mr Michael Pillay

Maddison Drennan
Yijian (David) Guo (ITD)
Purvi Kapur (IWD)
Crystal Kondoulis (IWD)

Emma Kunjasich
Cameron McLean
Adwithiya Puri
Annanya Puri
Hollie Skinner (IWD)

Aimee Stanton (IWD)
Jade Thurley (IWD)*
Luke Welsh (ITD)
Dieter Zadow



United Nations Workshop & "Whats Up West" Youth Conference

Coordinator and Award Presenter: Mr Michael Pillay



Aarna Agrawal
William Ballard
Krittika Biswas
Natasha Chandler
Grace Deng
Siya Dhawan
Maddison Drennan
Yasin Ganje
Mangesh Jagtap
Vaibhav Jain
Kevin Hangeeol Jeong

Sarina Karimi
Joshua Kim
Emma Kunjasich
Jacquelyn Ly
Liam Mai
Kiara McLean (WSYC)
Muskan Nazari
Thien (Kim) Nguyen
Isioma Oba
Makenzie O'Shea
Daniel Parr

Kiara Pemberton (UN)
Lejla Pervanic (WSYC)
Anannya Puri
Emma Ralla
Nibhas Samudrala (UN)
Nikhil Talagadivi
Nipun Talagadivi
Nahyeon Thomas
Valerie Wijaya
Daniel Zolmajdi
Wasay Zuberi



Library News



Many new books have come into circulation after our annual stocktake. Stocktake allows us to check that all library resources are in their correct place and to weed out any old or out of date resources. Just a reminder that our students may borrow five books to read over the Christmas holidays.

Students may purchase great Christmas presents through the Scholastic book club. A brochure containing discounted Scholastic items may be collected from the library circulation desk.

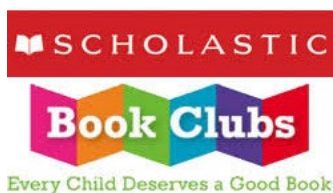

The library hosted many of the special provisions exams during the HSC. Our students are to be commended for keeping extremely quiet while the exams were taking place. Our new Year 12 students have been taking up the opportunity to study now that they have access to the Year 12 library study spaces.



More classes are visiting the library for reading and borrowing sessions now that their formal exams have been completed.



Left: 7 Diamond students in the library on our comfortable furniture enjoying a lesson on survival fiction.

Mrs K Alexander
Teacher Librarian

Our **free E-book collection** may be easily accessed by installing an app called **ePlatform**. Students may borrow two books for two weeks via this online resource.

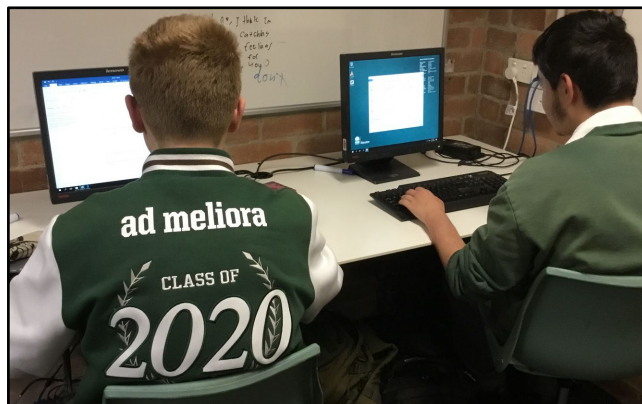

Above: Year 12 studying with some students wearing their new jackets

Robotics News

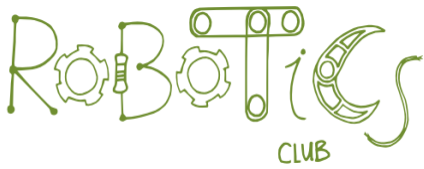

24 Students have enjoyed using their free creative kids voucher to attend a four week autonomous car robotics course on Wednesday afternoons. They have used scratch coding to program the multi-sensored Altino Robotics cars to drive and avoid various obstacles. The external company teaching our students has been impressed by the wonderful behaviour and respect shown by our students. Hopefully we will be able to run an advanced coding course in 2020.

Our school has booked the Department of Education's High school Lego Mindstorms Robotics kit for first term, 2020. This will enable some of our students to have the opportunity to complete a robotics course during Sport for 8 weeks. These kits may be configured to create many different robots that move in a variety of ways to solve real world problems.



Above: Students in the Robotics Club, mastering the Altino Robot Car



CODE WITH ALTINO



Our annual Sphero robotics competition winner will be announced next week. Students will be required to program the Sphero robots to create a Spirograph by attaching a whiteboard marker to a cup that sits over the robot. The prize for our winners will be a \$50 JB Hi-Fi voucher.

Mrs K Alexander
Robotics Coordinator

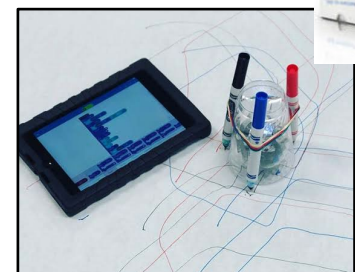

Above: Example of a Sphero Spirograph maker

Above and right: Example of Lego Mindstorms Robots

Student News

Josh Singh was named *NSW Under 15s volleyball, Most Improved Player* at the awards night this term. He pictured right with his state coach, Mladen.

Congratulations Josh, what a great year of sporting achievement!



Year 10 Industrial Technology - Timber

This term students complete their major practical project. The brief was to design and construct a bedside table, incorporating decorative elements such as a routed profile around the top, tapered legs or interesting frame. The variety of designs was wide, and quality high across the board with students demonstrating a new range of skills. These included using jigs to create tapers and mitres on the bandsaw and creating a mortise and tenon type joint using the domino joiner. For some it was a bittersweet experience, as not all students in the class have chosen to continue with timber next year. We wish you all the best!



Year 9 Design & Technology

Year 9 Design students were given the task of designing their dream bedroom for their major project. Ideally this would be using their existing floorplan, but without a budget, their options were pretty well unlimited. Not to relax on their academic requirements, the task was formed in 3 parts: a portfolio documenting their identification of user requirements, research and justification of design choices; a mood board communicating their idea through visual inspiration, floorplan, perspective drawing, colour scheme and material samples; and finally a scale model of their room complete with furniture to match. Most chose to complete their models using a combination of foam board, balsa wood, foam and fabric, however Alexis W used skills learnt through Graphics Technology to create her model digitally. What some students managed to achieve is pretty amazing!



Year 9 Graphics Technology

Year 9 Graphics students were once again challenged to produce something spectacular. This time they used the sharing functions in Fusion 360, their Computer Aided Design (CAD) software, to work collaboratively to create computer models of a physical object. On this occasion, they worked in groups of 3 to model toy trucks. Students worked independently to accurately model individual components before assembling these parts into one cohesive model. For each part, they had to add realistic materials and appearance (known as rendering) as well as generate technical drawings. The results speak for themselves!

*photos of original models included for comparison

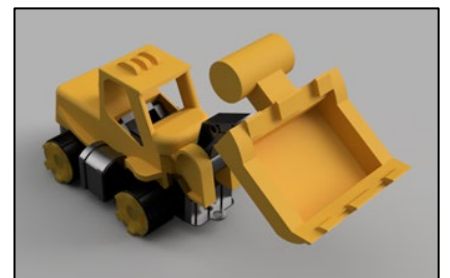
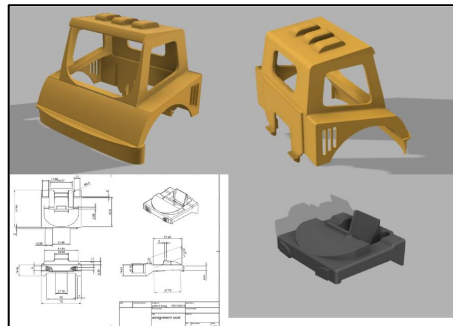
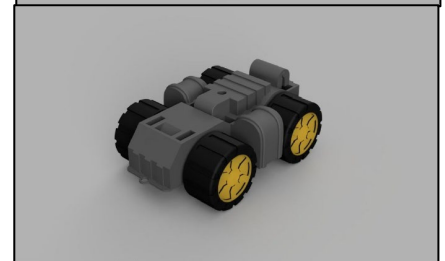
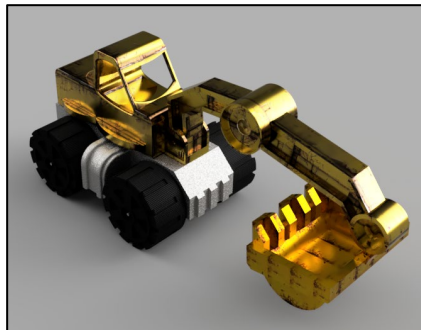
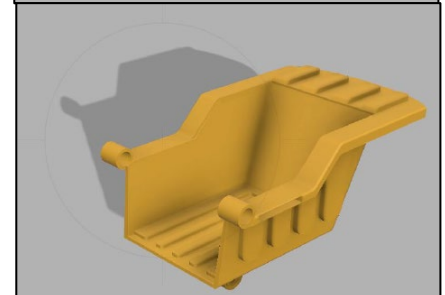
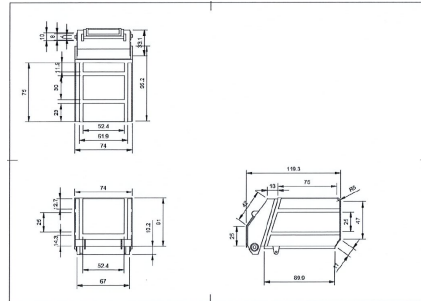

COMMUNITY NOTICES

Experience Excellence at
Cumberland High School's

2020 OPEN EVENING

MONDAY 24TH FEBRUARY
5:30PM – 8:00PM

Cumberland High School
183 Pennant Hills Road, Carlingford NSW 2118
(Entry via Dumore Avenue)



Cumberland High School provides an extensive range of academic and vocational opportunities delivered by our professional, experienced and highly committed teachers.

Further Enquiries P: 02 9871 7718 www.cumberland-h.schools.nsw.gov.au  Cumberland High School – Official

d



THE CAGETM CHALLENGE

Starlight
children's foundation

A SOCCER CHALLENGE LIKE YOU NEVER EXPERIENCED BEFORE

TEAMS OF 3/MEDALS/MVP U7S TO U14S
10AM - 4PM/SATURDAY 7/12/19
VANESSA STREET – BEVERLY HILLS
\$20 PER PLAYER/MUSIC & BBQ
REGISTER NOW AT INFO@SOCCERDEBRAZIL.COM

***FUNDRAISING EVENT FOR THE STARLIGHT FOUNDATION**

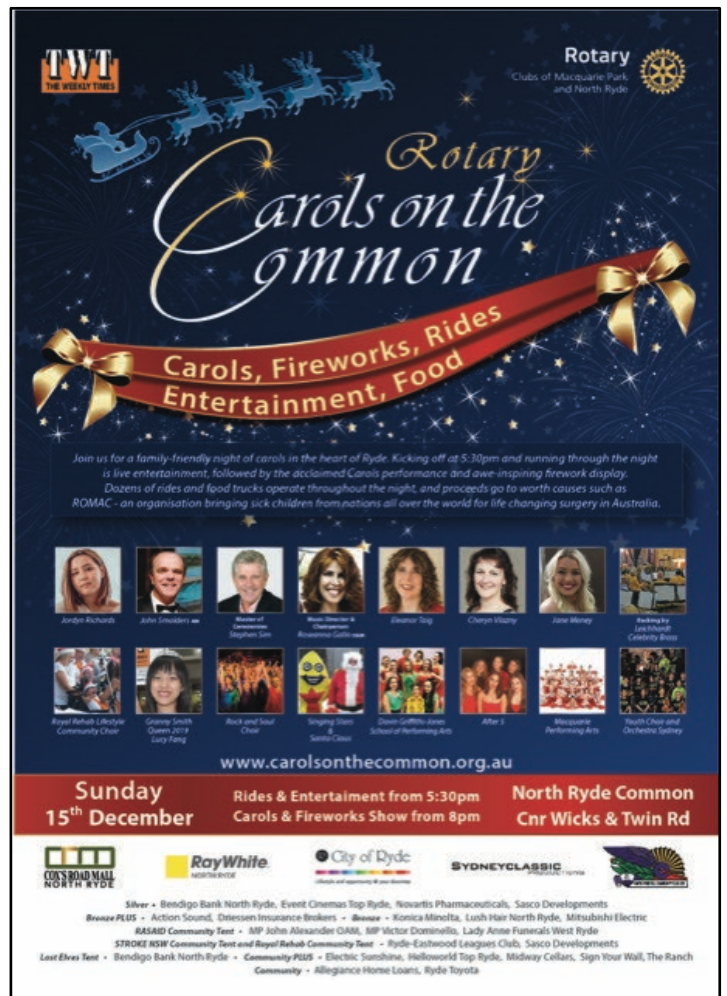

















Rotary
Clubs of Marquarie Park and North Ryde

Rotary Carols on the Common

Carols, Fireworks, Rides Entertainment, Food

Join us for a family-friendly night of carols in the heart of Ryde. Kicking off at 5:30pm and running through the night is live entertainment, followed by the acclaimed Carols performance and awe-inspiring fireworks display. Dozens of rides and food trucks operate throughout the night, and proceeds go to worthy causes such as ROMAC - an organisation bringing sick children from nations all over the world for life changing surgery in Australia.

 Aurora Richards	 John Lindner	 Michaela & Stephen	 Thea & Benjamin	 Eleanor	 Cheryl	 Jane	 Rotary Club of North Ryde
 Royal Rehab	 Garry & Lucy	 Rock and Soul	 Singing Stars	 Down Griffiths	 After 5	 Missy	 Youth Choir

www.carolsonthecommon.org.au

Sunday 15th December Rides & Entertainment from 5:30pm
Carols & Fireworks Show from 8pm

North Ryde Common
Cnr Wicks & Twin Rd

SPONSORS: COSSPOD MALL NORTH RYDE, RayWhite, City of Ryde, SYDNEYCLASSIC

Supporters: Silver - Bendigo Bank North Ryde, Event Cinemas Top Ryde, Novartis Pharmaceuticals, Sasco Developments, Breeze PLUS - Action Sound, Otesen Insurance Brokers, Bazaar - Konica Minolta, Lush Hair North Ryde, Mitsubishi Electric, RASMD Community Trust - MP John Alexander OAM, MP Victor Dominello, Lady Anne Funerals West Ryde, STROKE NSW Community Trust and Royal Rehab Community Trust - Ryde-Eastwood Leagues Club, Sasco Developments, Last Elves Trust - Bendigo Bank North Ryde - Community PLUS - Electric Sunshine, Hollowford Top Ryde, Midway Cellars, Sign Your Wall, The Ranch Community - Allegiance Home Loans, Ryde Toyota